



## 64-channel Scanning A/D Converter

### Overview

The VT1413C 64-channel Scanning A/D is a C-size, single slot, register-based VXI module. It is designed for high-performance data acquisition and computer-aided test applications. The key requirements of these applications are high-speed scanning, 16-bit resolution, high accuracy (0.01% of reading), 4 mV to 16 V full-scale input (60 V with VXI Technology VT1513A attenuator SCP), 64 kSample dual-ported FIFO buffer for fast data transfers, current value table for online monitoring, and automatic self-calibration. The available ranges are determined by the SCP used. An SCP is required for every input. Each SCP normally supplies input signal conditioning for eight (8) channels. See the individual SCP Data Sheet for more information.

The unique design of the analog subsystem provides a new level of density by combining a 16-bit A/D with a 64-channel differential FET multiplexer. Up to eight Signal Conditioning Plug-ons (SCPs), most with eight channels each, can be added to the VT1413C to provide additional capabilities (i.e., direct input, 10 Hz low-pass filtering, fixed gain/filter per channel, etc.).

Refer to the VXI Technology Website for instrument driver availability and downloading instructions, as well as for recent product updates, if applicable.

### Multifunctional Measurement Capability

This module provides multifunction measurement capability within individual scans without any configuration re-programming. These include dc voltage, temperature, resistance, and strain.

### Comprehensive Signal Conditioning On Board

A full range of signal conditioning is provided by optional Signal Conditioning Plug-on daughter boards (SCPs) that mount inside the VT1413C. Most SCPs buffer the signal to be measured and filter or amplify it before presenting it to the VT1413C's FET multiplexer and A/D converter. Other available SCPs provide more advanced functions such as sample-and-hold and strain bridge excitation and completion.

The SCPs supported by the VT1413C are:

Model No.	Description
VT1501A	8-channel Direct Input SCP
VT1502A	8-channel 7 Hz Low-pass Filter SCP
VT1503A	8-channel Programmable Filter and Gain SCP
VT1505A	8-channel Current Source SCP
VT1506A	8-channel 120 $\Omega$ Strain Completion & Excitation SCP
VT1507A	8-channel 350 $\Omega$ Strain Completion & Excitation SCP

# Features

Comprehensive Signal Conditioning On Board

Flexible Scanning/Auto Sequencing

High-speed Data Transfers into Controller

On-board Data Reduction and hi/low Limit Checking

Signal Digitizing to 100 kHz Sampling Rate ( \* )

(\* 100 kSa/s maximum sampling/scanning rate divided by the number of channels in the scan list, which can be 1 to 64. )

## 64-channel Scanning A/D Converter

Model No.	Description
VT1508A	8-channel x16 Gain & 7 Hz Low-Pass Fixed Filter SCP
VT1509A	8-channel x64 Gain & 7 Hz Low-Pass Fixed Filter SCP
VT1510A	4-channel Sample & Hold Input SCP
VT1511A	4-channel Transient Strain SCP
VT1512A	8-channel 25 Low-Pass Hz Fixed Filter SCP
VT1513A	8-channel Divide-by-16 Fixed Attenuator & 7 Hz Low-pass Filter SCP
VT1518A	4-wire Resistance Measurement SCP

Refer to the information on each individual SCP for more details.

### Flexible Scanning/Auto Sequencing

Measurement scans can be made in any channel order using any function on any channel, all at full speed, including auto-ranging. Up to four unique scan lists, each with up to 1,024 channel entries, can be stored in RAM and selected on the fly with a single software command. In addition, these scan lists can be automatically sequenced with a unique auto sequencing scan list. Lists can be sequenced so as to simplify the scanning of channels at different rates.

### Other Features

#### High-speed Data Transfers into Controller

Data transfer speed has been greatly improved because multiple VT1413Cs can scan in parallel at full speed and then sequentially transfer data over the VXI backplane in D16 or D32 format at rates that match even the fastest embedded VXI computer. The data is transferred in computer-ready, IEEE-754, 32-bit floating-point real engineering unit format. Two on-board DSPs facilitate overall performance. The FIFO RAM is a dual-ported high-speed buffer that stores up to 64,000 samples until the controller is ready for efficient fast data transfer. For online monitoring, the Current Value Table RAM contains the most recently measured values for each channel in use. The CVT and FIFO RAMs can be accessed asynchronously.

#### On-board Data Reduction and Hi/Low Limit Checking

Averaging can be enabled on a scan basis to provide averaging for each channel over two to 256 samples in binary steps. The averaged data goes to both the CVT and the FIFO buffer. The maximum sample rate is 1.5 kSa/s per channel for 64 channels, although higher rates are possible with fewer channels. When averaging multiple channels in a scan list, scan list switching and auto-ranging are not allowed. This would distort the average. Individual high and low limits per channel can be downloaded to the VT1413C in engineering units format. If a limit is exceeded, an interrupt or trigger line can be pulled and the limit register can be read to determine the out-of-limit channel. A cumulative mode can be selected that holds the

channel number of any out-of-limit reading since the last INIT command. The FIFO buffer can then be read to determine the actual out-of-limit readings.

### Signal Digitizing

The VT1413C is suitable for digitizing of multichannel transient signals up to a 1 kHz sampling rate when used with the VT1510A 4-channel Sample & Hold Input SCP anti-aliasing filters. Digitizing higher frequency signals using the VT1501A 8-channel Direct Input SCP will require the use of external anti-aliasing filters. The scan trigger, either internally or externally generated, is used to initiate the channel samples controlled by the internal sample timer. The typical scan trigger jitter time is  $\pm 100$  ps.

### Signal Conditioning Plug-ons

A Signal Conditioning Plug-on (SCP) is a small daughter board that mounts on VXI Technology's VXI scanning measurement and control modules. These SCPs provide a number of input and output functions. Several include gain and filtered analog inputs for measuring electrical and sensor-based signals. Refer to the information on each individual SCP for more details.

### Voltage Measurements

Use any of the following SCPs with the VT1413C to make voltage measurements: VT1501A, VT1502A, VT1503A, VT1508A, VT1509A, VT1512A, or VT1513A.

### Temperature Measurements

Any of the input SCPs can be used to make temperature measurements with thermocouples, thermistors, or RTDs, but the VT1503A, VT1508A, VT1509A SCPs provide higher accuracy with thermocouples.

### Resistance Measurements

Resistance is measured using the VT1505A 8-channel Current Source SCP and an input SCP or the VT1518A 4-wire Resistance Measurement SCP. Measurements are made by applying a dc current to the unknown and measuring the voltage drop across the unknown. The current source is provided through the VT1505A.

### Static Strain Measurements

The VT1506A and VT1507A SCPs provide a convenient way to measure a few channels of static strain. When using the VT1506A/VT1507A for bridge completion, a second SCP is required to make the measurement connection. You can use the following SCPs for this type of static strain measurements:

## 64-channel Scanning A/D Converter

- **VT1503A 8-channel Programmable Filter/Gain SCP**
- **VT1506A 8-channel 120 Ω Strain Completion & Excitation SCP**
- **VT1507A 8-channel 350 Ω Strain Completion & Excitation SCP**
- **VT1508A 8-channel 7 Hz Fixed Filter & x16 Gain SCP**
- **VT1509A 8-channel 7 Hz Fixed Filter & x64 Gain SCP**

For applications requiring large channel counts of strain measurement, the EX1629 provides a more cost effective approach to static (and dynamic) strain measurements.

By using the latest surface mount technology in circuit design, it has been possible to combine 48 channels of strain conditioning into a single 19-inch rackmount enclosure that is only 1 ¾ inches high. This includes programmability of individual strain bridge configuration and completion, and an on-board calibration source.

### Transient Measurements

When making higher speed measurements, a vital issue often is the time skew between channels. Ideally, in many applications, the sampled data is needed at essentially the same instant in time. The intrinsic design of the VT1413C provides scanning of 64 channels with maximum skew of 640 μs between the first and last channels, far less than most sampled data systems.

### Transient Voltage Measurements

The VT1510A provides basic sample-and-hold capabilities on four channels. Six-pole Bessel filters provide alias and alias-based noise reduction while giving excellent transient response without overshoot or ringing. The VT1510A can be used in strain applications primarily where the bridge is external.

### Transient Strain Measurements

The VT1511A and VT1521, double-wide SCPs, have all the capabilities of the VT1510A but add on-board bridge excitation and completion functions. The four direct input channels are used for monitoring the bridge excitation. A maximum of four SCPs (16 channels) can be installed on a VT1413C.

### Automated Calibration for Better Measurements

The VT1413C offers superior calibration capabilities that provide more accurate measurements. Periodic calibration of the scanning A/D is accomplished by connecting an external voltage measurement standard (such as a highly accurate multimeter) to the inputs of the scanning A/D. This external

standard first calibrates the on-board calibration source. Then built-in calibration routines use the on-board calibration source and on-board switching to calibrate the entire signal path from the scanning A/D's input, through the signal conditioning plug-ins (SCPs) and FET MUX, to the A/D itself. Subsequent daily or short-term calibrations of this same signal path can be quickly and automatically done using the internal calibration source to eliminate errors introduced by the signal path through the SCPs and FET MUX, or by ambient temperature changes. All 64 channels can be quickly and productively calibrated to assure continued high-accuracy measurements.

In addition to the calibration of the signal path within the scanning A/D, the VT1413C allows you to perform a "Tare Cal" to reduce the effects of voltage offsets and IR voltage drops in your signal wiring that is external to the scanning A/D. The Tare Cal uses an on-board D/A to eliminate these voltage offsets. By placing a short circuit across the signal or transducer being measured, the residual offset can be automatically measured and eliminated by the D/A. Tare Cal should not be used to eliminate the thermoelectric voltage of thermocouple wire on thermocouple channels.

### Configuration

Twelve VT1413C modules may be used in a 13-slot, C-size mainframe for a total of 768 channels. A C-size configuration using MXIbus allows you to link together multiple mainframes on a single backplane for larger scanning A/D systems. Note: For field wiring, the use of shielded twisted pair wiring is highly recommended.

### Timing Signals

<b>Timing:</b>	Scan-to-scan timing and sample-to-sample timing can be set independently.
<b>Scan triggers:</b>	Can be derived from a software command or a TTL level from other VXI modules, internal timer, or external hardware. Typical latency 175 μs.
<b>Synchronization:</b>	Multiple VT1413C modules can be synchronized at the same rate using the TTL trigger output from one VT1413C to trigger the others.
<b>Alternate synchronization:</b>	Multiple VT1413C modules can be synchronized at different integer-related rates using the scan timer/N mode and the TTL trigger output from one VT1413C module to trigger the others.

## 64-channel Scanning A/D Converter

### Scan Triggers

<b>Internal:</b>	100 $\mu$ s to 6.5536 s
<b>Resolution:</b>	100 $\mu$ s
<b>Trigger count:</b>	1 to 65535 or infinite

### Sample Timer

<b>Range:</b>	10 $\mu$ s to 32768 ms
<b>Resolution:</b>	0.5 $\mu$ s

### Measurement Specifications

The following specifications include the SCP and scanning A/D performance together as a unit. Accuracy is stated for a single sample. Averaging multiple samples will improve accuracy by reducing noise of the signal. The basic VT1413C scanning A/D has a full-scale range of  $\pm 16$  V and five auto-ranging gains of x1, x4, x16, x64, and x256. An SCP must be used with each eight channel input block to provide input protection and signal conditioning. Refer to the information on each individual SCP for measurement specifications.

**Measurement resolution:** 16 bits (including sign)

**Maximum reading rate:** 100 kSa/s divided by the number of channels in the scan.

For example:  
 $100k/64 = 1.56$  kSa/s per channel  
 $100k/16 = 6.25$  kSa/s per channel

**Memory:** 64 kSa

**Maximum input voltage:** Normal mode plus common mode

Operating:  $\pm 16$  V peak  
 Damage level:  $\pm 42$  V peak

**Maximum common mode voltage:**

Operating:  $\pm 16$  V peak  
 Damage level:  $\pm 42$  V peak

**SCP input impedance:** 100 m $\Omega$  differential

**Maximum tare cal offset:** 62.5 mV range  $\pm 75\%$  of full-scale other ranges  $\pm 25\%$  of full-scale

### Jitter

Phase jitter scan-to-scan: 80 ps rms  
 Phase jitter card-to-card: 41 ns peak 12 ns rms



### Measurement Accuracy

Specifications are 90 days, 23  $^{\circ}$ C  $\pm 1$   $^{\circ}$ C, with \*CAL done after a 1 hr warm-up and CAL:ZERO done within 5 minutes. Note: Beyond the 5 min limitation and CAL:ZERO not done, apply the following drift error: Drift = 10  $\mu$ V/ $^{\circ}$ C  $\div$  SCP gain, per  $^{\circ}$ C change from CAL:ZERO temperature.

### Accuracy Data

Measurement accuracy is dependent upon the SCP module used. Refer to the accuracy tables and graphs for the individual SCP to determine the overall measurement accuracy.

Many definitions of accuracy are possible. Here we use single-shot with 3 sigma noise. To calculate accuracy assuming temperature is held constant within  $\pm 1^{\circ}$ C of the temperature at calibration, the following formula applies:

$$\text{Single Shot } 3\sigma = \pm(\sqrt{((\text{GainError})^2 + (\text{OffsetError})^2 + (3\sigma_{\text{noise}})^2)})$$

### Correcting for Temperature

To calculate accuracy over temperature range outside the  $\pm 1$   $^{\circ}$ C range, results after \*CAL are given by replacing each of the above error terms as follows:

Replace  $(\text{GainError})^2$  with  $(\text{GainError})^2 + (\text{GainTempco})^2$   
 Replace  $(\text{OffsetError})^2$  with  $(\text{OffsetError})^2 + (\text{OffsetTempco})^2$

### Power Available for SCPs

$\pm 24$  V: 1 A  
 5 V: 3.5 A

## 64-channel Scanning A/D Converter, C-Size

### VXI Characteristics

<b>VXI device type:</b>	Register based
<b>Data transfer bus:</b>	A16/A24
<b>Size:</b>	C
<b>Slots:</b>	1
<b>Connectors:</b>	P1/2
<b>Shared memory:</b>	n/a
<b>VXI buses:</b>	TTL Trigger bus
<b>Drivers:</b>	VXI <i>plug&amp;play</i> with Source Code

Instrument Drivers - See the VXI Technology Website [www.vxitech.com](http://www.vxitech.com) for driver availability and downloading.

### ACCESSORIES

73-0024-002, Option 011 Screw Terminal Connector Block

73-0024-003, Option 013 Spring Clamp Terminal Connector Block

73-0024-004, Option A3F Interface to Rackmount Terminal Panel

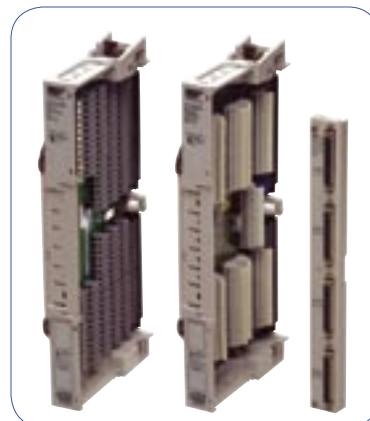

### Ordering Information

<b>VT1413C</b>	Scanning A/D Converter, includes spring clamp terminal block
<b>VT1413C-02</b>	Scanning A/D Converter, includes screw connector terminal block
<b>VT1413C-A3F</b>	Interface to rackmount terminal panel
<b>VT1501A</b>	8-channel Direct Input SCP
<b>VT1502A</b>	8-channel 7 Hz Low-pass Filter SCP
<b>VT1503A</b>	8-channel Programmable Filter/Gain SCP
<b>VT1505A</b>	8-channel Current Source SCP
<b>VT1506A</b>	8-channel 120 Ω Strain Completion & Excitation SCP
<b>VT1507A</b>	8-channel 350 Ω Strain Completion & Excitation SCP
<b>VT1508A</b>	8-channel x16 Gain & 7 Hz Fixed Filter SCP
<b>VT1509A</b>	8-channel x64 Gain & 7 Hz Fixed Filter SCP
<b>VT1510A</b>	4-channel Sample & Hold Input SCP
<b>VT1511A</b>	4-channel Transient Strain SCP
<b>VT1512A</b>	8-channel 25 Hz Fixed Filter SCP
<b>VT1513A</b>	8-channel ÷ 16 Fixed Attenuator & 7 Hz Low-pass Filter SCP
<b>VT1518A</b>	4-wire Resistance Measurement SCP
<b>VT1521</b>	4-channel High-Speed Bridge SCP

VT1413C

## Algorithmic Closed Loop Controller and Remote Channel Multifunction DAC

### Overview

The VT1415A and VT1422A are C-size, single-slot, VXI modules capable of either multi-function input/output (data acquisition) or powerful control capabilities. They serve as powerful data acquisition modules that handle analog input/output and digital input/output in both static and dynamic modes. The digital capability includes the ability to set or sense static states, to measure input frequency and period, to totalize, and to input or output PWM and FM signals. Refer to the VXI Technology Website for instrument driver availability and downloading instructions, as well as for recent product updates, if applicable.

### Algorithmic Closed Loop Controller - VT1415A

More powerful than PID controllers and easier to implement than large custom control systems, the VT1415A fills a unique niche in the data acquisition and control field, providing both control and precise data acquisition. Applications include:

- PID control of stimulus loops such as hydraulic actuators, levers, rotational devices as in structural test
- PID control of temperature, position, velocity, acceleration and more
- Complex control such as cascade loops in thermal cooling jackets, ratio
- Independent loops with multi-level alarms.

The design of the on-board, DSP firmware assures the user that all inputs, all calculations, and all outputs can be completed between scan triggers. This means there is no drift, or jitter in the critical time intervals that are used to calculate integrals and derivatives in control algorithms.

The firmware allows a user to employ pre-written PID control algorithms, modify them for specific application needs, or to write an application from scratch. Low duty-cycle connection to the host computer allows interaction between the host and real-time DSP so the user can update algorithms, change tuning constants, or do envelope control. Limited host computer interaction leads to very high performance (8-loops, update rate 1000/second per loop with simple PID calculation included).

### Multi-function Data Acquisition & Control Module - VT1422A

The VT1422A is a module that is essentially the same as the VT1415A and has all of the same data acquisition and control capabilities as the VT1415A, plus some additional features.



## Features

Powerful Data Acquisition Capability

Powerful Control Capability

Comprehensive On-board Signal Conditioning

Custom On-board DSP Program Development

Wide Choice of Input/Output Signal Types

Large Channel-count Strain Signal Conditioning and Measurement

The VT1422A Remote Channel Multi-Function DAC Module supports the VT1539A Remote Channel Signal Conditioning Plug-on and the VT1529B Remote Strain Signal Conditioning Unit to form a high-performance, but economical strain measurement system.

The VT1422A serves as the controller in this system, managing all the configuration, calibration, triggering of measurements, EU conversion, and calibration processes.

The main differences between the VT1415A and VT1422A are:

- The VT1422A has 40 kB of memory available for user algorithms; the VT1415A has 48 kB.
- If the only thing being done in an application is collection of strain data, the VT1422A user doesn't have to write an algorithm, as for the VT1415A.
- The VT1422A offers the same two Terminal Blocks as does the VT1415A.  
(Option 011 screw terminals and Option 013 spring clamp)

## Automated Calibration for Better Measurements

The VT1415A and VT1422A offer superior calibration capabilities that provide more accurate measurements. Periodic calibration of the module's measurement inputs is accomplished by connecting an external voltage measurement standard (such as a highly accurate multimeter) to the inputs of the module. This external standard first calibrates the on-board calibration source. Then built-in calibration routines use the on-board calibration source and on-board switching to calibrate the entire signal path from the closed loop controller's input, through the signal conditioning plug-ons (SCPs) and FET MUX, to the A/D itself. Subsequent daily or short-term calibrations of this same signal path can be quickly and automatically done using the internal calibration source to eliminate errors introduced by the signal path through the SCPs and FET MUX or by ambient temperature changes. All input channels can be quickly and productively calibrated to assure continued high-accuracy measurements.

In addition to the calibration of the signal paths within the modules, the VT1415A and VT1422A allow you to perform a "Tare Cal" to reduce the effects of voltage offsets and IR voltage drops in your signal wiring that is external to the module. The Tare Cal uses an on-board D/A to eliminate these voltage offsets. By placing a short circuit across the signal or transducer being measured, the residual offset can be automatically measured and eliminated by the D/A. Tare Cal should not be used to eliminate the thermoelectric voltage of thermocouple wire on thermocouple channels.

## Algorithmic Closed Loop Controller and Remote Channel Multifunction DAC

### Flexibility with Deterministic Control

The VT1415A and VT1422A are digital sampling closed loop control systems that are complete in a single VXI module. All signal conditioning, process monitoring, control calculations, and control signals are handled on-board without the need for computer supervision. Once setup is done, the module is essentially free-running.

The inputs are updated at the beginning of each cycle and the outputs are updated at a later deterministic time in the cycle so that various paths in the control algorithm do not affect the loop timing. These steps are executed automatically and deterministically without need for intervention from a system computer.

### Other Features

#### Digital Sampling Closed Loop Control System

The VT1415A/VT1422A combine flexibility with deterministic control. Control algorithms for each of the loops can be the default PID calculation or a user-defined, downloaded, custom algorithm. The loop update rate is deterministically controlled by an internal clock so that variations in the algorithm execution times do not affect the loop cycle time.

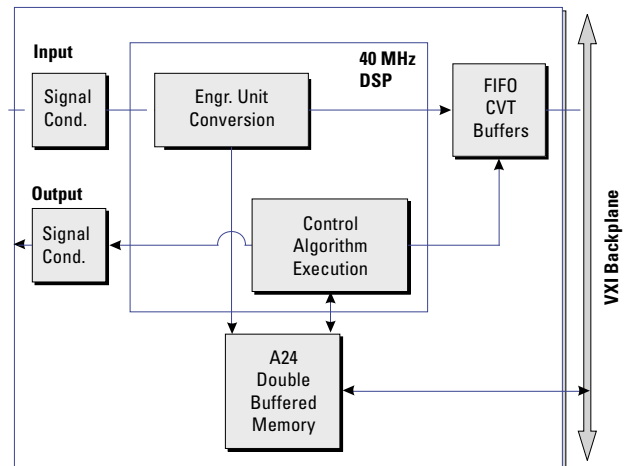

Digital Sampling Closed Loop System

### Powerful Control Capability

The control algorithm for each loop is easily developed by the user from a list of algebraic expressions and flow constructs such as IF, THEN, ELSE. Tuning is simplified because all of the constants in the algorithm as well as the algorithm itself can be updated on-the-fly. New values are double-buffered so there is no need to stop scanning the inputs or halt the algorithm execution.

## Algorithmic Closed Loop Controller and Remote Channel Multifunction DAC

The on-board 40 MHz pipelined DSP provides highly deterministic execution, making it easy to accurately predict cycle times. Engineering unit conversions for temperature, strain, resistance, and voltage measurements are made automatically without slowing down the algorithm execution speed.

### Wide Choice of Inputs/outputs

The inputs to the loop algorithm can be measured values from multiple channels, operator input values, outputs from other loops, or values from other subsystems. The VT1415A/VT1422A have a variety of signal conditioning plug-ons for making measurements of:

- Temperature, strain
- Voltage, current, resistance
- RPM, frequency, totalize
- Discrete levels, TTL, contact closures

In addition, the measured input values and the calculated output values can be stored in a 64,000-sample FIFO buffer and efficiently transferred to the controlling computer in blocks of data. With this feature, it is no longer necessary to waste resources by dedicating a data acquisition channel to monitor each control loop input and output. The result of any algorithm calculation can be an input for use by another loop or subsystem, or it can be a direct output of several different types. Among the choices of output are:

- Analog voltage
- Analog current
- Discrete levels (TTL)
- Pulse width modulation (TTL)

As an example of output flexibility, the pulse width modulation output has several modes. In the PWM free-run mode, the frequency or pulse width output rate is independent of the loop update rate and can be changed once per loop update cycle. The square wave mode provides a variable frequency, fixed 50% duty cycle output signal. The pulse-per-update mode provides a variable width pulse synchronized to the loop update cycle.

### Operator Control

Manual control can be implemented through a user software interface or external hardware, such as a potentiometer. Seamless transfer from auto to manual mode, or manual to auto is handled automatically by a set-point-tracking routine in the default PID algorithm code.

### Signal Conditioning Plug-Ons

A Signal Conditioning Plug-on (SCP) is a small daughter board that mounts on VXI Technology's VXI scanning measurement and control modules. These SCPs provide a number of input and output functions. Several include gain and filtered analog inputs for measuring electrical and sensor-based signals, as well as frequency, total event count, pulse-width modulation, toothed-wheel velocity, and digital state. Output functions include analog voltage and current D/As, 8- or 16-bit digital outputs, pulse output with variable frequency and PWM, and stepper motor control.

Refer to the information on each individual SCP for more details.

### Voltage Measurements

Use any of the following SCPs with the VT1415A/VT1422A to make voltage measurements: VT1501A, VT1502A, VT1503A, VT1508A, VT1509A, VT1512A, or VT1513A.

### Temperature Measurements

Any of the input SCPs can be used to make temperature measurements with thermocouples, thermistors, or RTDs, but the VT1503A/VT1508A/VT1509A SCPs provide higher accuracy with thermocouples.

### Resistance Measurements

Resistance is measured using either the VT1505A 8-channel Current Source SCP and an input SCP or the VT1518A 4-wire Resistance Measurement SCP. Measurements are made by applying a dc current to the unknown and measuring the voltage drop across the unknown.

### Static Strain Measurements

There are two ways to make static strain measurements.

The VT1506A and VT1507A SCPs provide a convenient way to measure a few channels of static strain. When using the VT1506A/VT1507A for bridge completion, a second SCP is required to make the measurement connection. You can use the following SCPs for this type of static strain measurements:

- VT1503A 8-channel Programmable Filter/Gain
- VT1506A 8-channel 120  $\Omega$  Strain Completion & Excitation
- VT1507A 8-channel 350  $\Omega$  Strain Completion & Excitation
- VT1508A 8-channel 7 Hz Fixed Filter & x16 Gain
- VT1509A 8-channel 7 Hz Fixed Filter & x64 Gain

## Algorithmic Closed Loop Controller and Remote Channel Multifunction DAC

For applications requiring large channel counts of strain measurement, the EX1629 provides a more cost effective approach to static (and dynamic) strain measurements.

Dynamic strain measurements are implemented by connecting the EX1629 to high-speed digitizers, such as the VXI Technology VT1432B and VT1433B.

Note: SCPs are also available for making dynamic strain measurements (VXI Technology VT1510A, VT1511A, and VT1521).

### Transient Measurements

When making higher speed measurements, a vital issue often is the time skew between channels. Ideally, in many applications, the sampled data is needed at essentially the same instant in time. While the intrinsic design of the VT1415A/VT1422A provides scanning of 64 channels, with maximum skew of 640  $\mu$ s between the first and last channel (far less than most sampled data systems), this still may not be small enough skew for some applications.

### Transient Voltage Measurements

The VT1510A provides basic sample-and-hold capabilities on four channels. Six-pole Bessel filters provide alias and alias-based noise reduction while giving excellent transient response without overshoot or ringing. The VT1510A can be used in strain applications primarily where the bridge is external.

### Transient Strain Measurements

The VT1511A, a double-wide SCP, has all the capabilities of the VT1510A but adds on-board bridge excitation and completion functions. The four direct input channels are used for monitoring the bridge excitation. A maximum of four SCPs (16 channels) can be installed on a VT1415A/VT1422A.

### Analog Output

Use the VT1531A for voltage outputs, and the VT1532A for current outputs. The VT1531A and VT1532A have eight (8) output channels available on each SCP.

A maximum of seven (7) VT1532A SCPs can be installed on each VT1415A/VT1422A due to power limitations. There are no power restrictions on the VT1531A.

### Digital I/O

Use the VT1533A Digital I/O SCP to provide two 8-bit input/output words.

### Frequency/Totalize/PWM

The VT1538A Enhanced Frequency/Totalize/PWM SCP provides eight (8) channels which can be individually configured as a frequency or totalizer input, or as a pulse width modulated output.

### Compact Packaging with Signal Conditioning

The VT1415A/VT1422A provide for configurable signal conditioned I/O with up to eight individual plug-ons for analog, digital, and frequency needs. The SCPs are:

- VT1501A 8-channel Direct Input SCP
- VT1502A 8-channel 7 Hz Low-pass Filter SCP
- VT1503A 8-channel Programmable Filter and Gain SCP
- VT1505A 8-channel Current Source SCP
- VT1506A 8-channel 120  $\Omega$  Strain Completion & Excitation SCP
- VT1507A 8-channel 350  $\Omega$  Strain Completion & Excitation SCP
- VT1508A 8-channel x16 Gain & 7 Hz Fixed Filter SCP
- VT1509A 8-channel x64 Gain & 7 Hz Fixed Filter SCP
- VT1510A 4-channel Sample & Hold Input SCP
- VT1511A 4-channel Transient Strain SCP
- VT1512A 8-channel 25 Hz Fixed Filter SCP
- VT1513A 8-channel Divide-by-16 Fixed Attenuator & 7 Hz Low-pass Filter SCP
- VT1518A 4-wire Resistance Measurement SCP
- VT1521 4-channel High-speed Bridge SCP
- VT1531A 8-channel Voltage Output SCP
- VT1532A 8-channel Current Output SCP
- VT1533A 16-bit Digital I/O SCP
- VT1536A 8-bit Isolated Digital I/O SCP
- VT1538A Enhanced Frequency/Totalize/PWM SCP
- VT1539A Remote Channel SCP (VT1422A only)

### Product Specifications

## Algorithmic Closed Loop Controller and Remote Channel Multifunction

### Timing Signals

<b>Timing:</b>	Scan-to-scan timing and sample-to-sample timing can be set independently.
<b>Scan triggers:</b>	Can be derived from a software command or a TTL level from other VXI modules, internal timer, or external hardware. Typical latency 17.5 $\mu$ s.
<b>Synchronization:</b>	Multiple VT1415A/VT1422A modules can be synchronized at the same rate using the TTL trigger output from one VT1415A/VT1422A to trigger the others.
<b>Alternate synchronization:</b>	Multiple VT1415A/VT1422A modules can be synchronized at different integer-related rates using the ALG:SCAN:RATIO command and the TTL trigger output from one VT1415A/VT1422A module to trigger the others.

### Scan Triggers

<b>Internal:</b>	100 $\mu$ s to 6.5536 s
<b>Resolution:</b>	100 $\mu$ s
<b>Trigger count:</b>	1 to 65535 or infinite
<b>Sample Timer Range:</b>	VT1415A: 10 $\mu$ s to 32768 ms VT1422A: 40 $\mu$ s to 32768 ms
<b>Resolution:</b>	0.5 $\mu$ s

### Measurement Specifications

The following specifications include the SCP and scanning A/D performance together as a unit. Accuracy is stated for a single sample. Averaging multiple samples will improve accuracy by reducing noise of the signal. The basic VT1415A scanning A/D has a full-scale range of  $\pm 16$  V and five auto-ranging gains of x1, x4, x16, x64, and x256. An SCP must be used with each eight channel input block to provide input protection and signal conditioning.

**Note: For field wiring, the use of shielded twisted pair wiring is highly recommended.**

**Measurement resolution:** 16 bits (including sign)

**Maximum reading rate:** VT1415A: Up to 56 kSa/s dependent upon configuration  
VT1422A: Up to 25 kSa/s dependent upon configuration

**Memory:** 64 kSamples

**Maximum input voltage:** Normal mode plus common mode

Operating:  $\pm 16$  V peak  
Damage level:  $\pm 42$  V peak

**Maximum common mode voltage:**

Operating:  $\pm 16$  V peak  
Damage level:  $\pm 42$  V peak

**SCP input impedance:** 100 M $\Omega$  differential

**Maximum tare cal offset:** 62.5 mV range  $\pm 75\%$  of full scale, other ranges  $\pm 25\%$  of full-scale

### Jitter:

**Phase jitter scan-to-scan:** 80 ps rms

**Phase jitter card-to-card:** 41 ns peak 12 ns rms

### Measurement Accuracy

Typically  $\pm 0.01\%$  of input level; varies with the SCP used. Specifications are 90 days, 23  $^{\circ}$ C  $\pm 1$   $^{\circ}$ C, with \*CAL done after a 1 hr warm-up and CAL:ZERO done within 5 minutes. Note: Beyond the 5min. limitation and CAL:ZERO not done, apply the following drift error: Drift = 10  $\mu$ V/ $^{\circ}$ C  $\div$  SCP gain, per  $^{\circ}$ C change from CAL:ZERO temperature.

### Accuracy Data

Measurement accuracy is dependent upon the SCP module used. Refer to the accuracy tables and graphs for the individual SCP to determine the overall measurement accuracy.

Many definitions of accuracy are possible. Here we use single-shot with 3 sigma noise. To calculate accuracy assuming temperature is held constant within  $\pm 1$   $^{\circ}$ C of the temperature at calibration, the following formula applies:

$$\text{Single Shot } 3\sigma = \pm\sqrt{(\text{GainError})^2 + (\text{OffsetError})^2 + (3\sigma \text{ noise})^2}$$

### Correcting for Temperature

## Algorithmic Closed Loop Controller and Remote Channel Multifunction

To calculate accuracy over temperature range outside the  $\pm 1$  °C range, results after \*CAL are given by replacing each of the above error terms as follows:

Replace  $(GainError)^2$   
with  $(GainError)^2 + (GainTempco)^2$

Replace  $(OffsetError)^2$   
with  $(OffsetError)^2 + (OffsetTempco)^2$

### Loop Control Specifications

**Number of loops:** 1 to 32

**Default control algorithm type:** PID

**Maximum VT1415A loop update rate for default PID algorithm:**

(Note: VT1422A maximum sample rate is 25 kSamples/s, compared to 56 kSa/s for the VT1415A. The loop speeds of the VT1422A are reduced in same ratio.)

1 loop:	3 kHz
8 loops:	1 kHz
32 loops:	250 Hz

### Custom algorithm development:

**Language:** Subset of C programming language including if-then-else, most math and comparison operations.

**Variable types:** Scalar local and global

variables, array local and global variables.

**Intrinsic functions:**

interrupt( ), writefifo( ), writecv( ), writeboth( ), min( ), max( ), abs( ).

**Other functions:**

Create own custom functions to handle transcendental operations.

### I/O General

A total of eight (8) Signal Conditioning Plug-ons (SCPs) can be installed in most combinations of input or output configurations on a single VT1415A/VT1422A.

### Power Available for SCPs

$\pm 24$ V:	1.0 A
5 V:	3.5 A

### General Specifications

**VXI device type:** A16, slave only, Register based

**Size:** C

**Slots:** 1

**Connectors:** P1/2

**Shared memory:** n/a

**VXI buses:** TTL Trigger bus

**Drivers:** VXIplug&play with Source Code

**Instrument Drivers - See the VXI Technology Website [www.vxitech.com](http://www.vxitech.com) for driver availability and downloading.**  
VT1415A Algorithmic Closed Loop Controller,

## Algorithmic Closed Loop Controller and Remote Channel Multifunction

### Ordering Information

	Includes Spring Clamp Terminal Block	<b>VT1415A-02</b>	Algorithmic Closed Loop
	Controller, Includes Screw Connector Terminal Block		
<b>VT1415A-A3F</b>	Interface to rackmount terminal panel		
<b>VT1422A</b>	Remote Channel Multi-function Data Acquisition & Control Module		
<b>VT1422A-001</b>	16-Port RJ-45 Connector Block (supports VT1415A also)		
<b>VT1422A-011</b>	Screw Terminal Connector Block (supports VT1415A also)		
<b>VT1422A-013</b>	Spring Clamp Terminal Connector (supports VT1415A also)		
<b>VT1501A</b>	8-channel Direct Input SCP		
<b>VT1502A</b>	8-channel 7 Hz Low-pass Filter SCP		
<b>VT1503A</b>	8-channel Programmable Filter/Gain SCP		
<b>VT1505A</b>	8-channel Current Source SCP		
<b>VT1506A</b>	8-channel 120 $\Omega$ Strain Completion & Excitation SCP		
<b>VT1507A</b>	8-channel 350 $\Omega$ Strain Completion & Excitation SCP		
<b>VT1508A</b>	8-channel x16 Gain & 7 Hz Fixed Filter SCP		
<b>VT1509A</b>	8-channel x64 Gain & 7 Hz Fixed Filter SCP		
<b>VT1510A</b>	4-channel Sample & Hold Input SCP		
<b>VT1511A</b>	4-channel Transient Strain SCP		
<b>VT1512A</b>	8-channel 25 Hz Fixed Filter SCP		
<b>VT1513A</b>	8-channel $\div$ 16 Fixed Attenuator & 7 Hz Low-pass Filter SCP		
<b>VT1518A</b>	4-wire Resistance Measurement SCP		
<b>VT1521</b>	4-channel High-Speed Bridge SCP		
<b>VT1531A</b>	8-channel Voltage Output SCP		
<b>VT1532A</b>	8-channel Current Output SCP		
<b>VT1533A</b>	16-bit Digital I/O SCP		
<b>VT1536A</b>	8-bit Isolated Digital I/O SCP		
<b>VT1538A</b>	Enhanced Frequency/Totalize/PWM SCP		
<b>VT1539A</b>	Remote Channel Signal Conditioning Plug-on (VT1422A only)		

VT1415A/VT1422A

### ACCESSORIES

- 73-0025-002 Option 011 Screw Terminal Connector Block
- 73-0025-003 Option 013 Spring Clamp Terminal Connector Block
- 73-0025-004 Option A3F Interface to Rackmount Terminal Panel

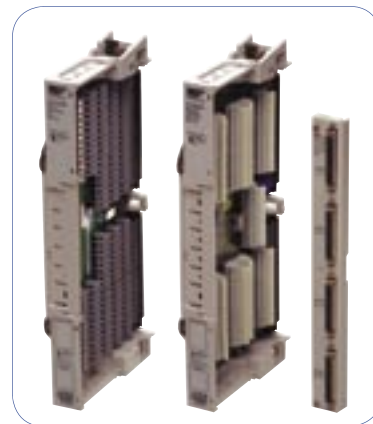



## Multifunction<sup>Plus</sup> Measurement and Control Module

### Overview

The VXI Technology VT1419A Multifunction<sup>Plus</sup> Measurement and Control module is a C-size, single slot, register-based VXI module. It is ideal for mixed sensor and mixed signal data acquisition and control for design verification of electromechanical components and assemblies.

The flexibility in configuring with multiple Signal Conditioning Plug-ons (SCPs) allows for multiple test setups of mixed signals, both input and output, without adding extra VXI measurement modules. The integrated signal conditioning provides for more accurate and repeatable calibration and eliminates the need for separate signal conditioning carriers. The intelligent measurement and control allows for scalable configurations, on-board Engineering Unit (EU) conversion, and real-time decision making.

Refer to the VXI Technology Website for instrument driver availability and downloading instructions, as well as for recent product updates, if applicable.

### Compact Packaging with Signal Conditioning

The VT1419A provides for configurable signal conditioned I/O with up to eight individual plug-ons for analog, digital, and frequency needs. The SCPs supported by the VT1419A are:

- VT1501A 8-channel Direct Input SCP
- VT1502A 8-channel 7 Hz Low-pass Filter SCP
- VT1503A 8-channel Programmable Filter and Gain SCP
- VT1505A 8-channel Current Source SCP
- VT1506A 8-channel 120  $\Omega$  Strain Completion & Excitation SCP
- VT1507A 8-channel 350  $\Omega$  Strain Completion & Excitation SCP
- VT1508A 8-channel x16 Gain & 7 Hz Fixed Filter SCP
- VT1509A 8-channel x64 Gain & 7 Hz Fixed Filter SCP
- VT1510A 4-channel Sample & Hold Input SCP
- VT1511A 4-channel Transient Strain SCP
- VT1512A 8-channel 25 Hz Fixed Filter SCP
- VT1513A 8-channel Divide-by-16 Fixed Attenuator & 7 Hz Low-pass Filter SCP
- VT1518A 4-wire Resistance Measurement SCP
- VT1521 4-channel High-Speed Bridge SCP
- VT1531A 8-channel Voltage Output SCP
- VT1532A 8-channel Current Output SCP
- VT1533A 16-bit Digital I/O SCP
- VT1536A 8-bit Isolated Digital I/O SCP
- VT1538A Enhanced Frequency/Totalize/PWM SCP

### Wide Choice of Inputs/Outputs

The VT1419A has a variety of signal conditioning plug-ons for making measurements of:

- Temperature, strain
- Voltage, current, resistance
- RPM, frequency, totalize
- Discrete levels, TTL, contact closures

# Features

Comprehensive Signal Conditioning On-Board

Wide Choice of Input/Output Signal Types

Powerful Control Capability

On-board Data Reduction and Engineering Unit Conversion

Custom On-board DSP Program Development

## Multifunctional<sup>Plus</sup> Measurement and Control Module

In addition, the measured input values and the calculated output values can be stored in a 64,000-sample FIFO buffer and efficiently transferred to the controlling computer in blocks of data. A 500-element current value table is provided so user-written programs can post the latest reading or condition to the controlling computer. The result of any program calculation can be an input for use by another program or subsystem, or it can be a direct output of several different types. Among the choices of output are:

- Analog voltage
- Analog current
- Discrete levels (TTL)
- Programmable pulse width modulation (TTL)

As an example of output flexibility, the pulse width modulation output has several modes. In the PWM free-run mode, the frequency or pulse width output is independent of the update rate and can be changed once per loop update cycle. The square wave mode provides a variable frequency, fixed 50% duty cycle output signal. The pulse-per-update mode provides a variable width pulse synchronized to the update cycle.

### Powerful Decision Making Capability

The user-written programs are easily developed from a list of algebraic expressions and flow constructs such as IF-THEN-ELSE. Any variable (array or scalar) can be read or written on-the-fly. That is, new values are double-buffered so there is no need to stop scanning the inputs or halt the program execution.

The inputs to user programs can be measured values from multiple channels, operator input values, global variables from other programs, or values from other subsystems. The on-board DSP provides highly deterministic execution, making it easy to accurately predict cycle times. Engineering unit conversions for temperature, strain, resistance, and voltage measurements are made automatically without slowing down the algorithm execution speed.

### Custom Program Development

**Language:** subset of C, including if-then-else, most math and comparison operations.

**Variable types:** scalar local and global variables, array local and global variables.

**Intrinsic functions:** `interrupt( )`, `writefifo( )`, `writecv( )`, `writeboth( )`, `min( )`, `max( )`, `abs( )`.

Other functions: create your own custom functions to handle transcendental operations.

### Other Features

#### Automated Calibration for Better Measurements

The VT1419A offers superior calibration capabilities that provide more accurate measurements. Periodic calibration of the measurement and control module's measurement inputs is accomplished by connecting an external voltage measurement standard (such as a highly accurate multimeter) to the inputs of the measurement and control module. This external standard first calibrates the on-board calibration source. Then built-in calibration routines use the on-board calibration source and on-board switching to calibrate the entire signal path from the measurement and control module's input, through the signal conditioning plug-ons (SCPs) and FET MUX, to the A/D itself. Subsequent daily or short-term calibrations of this same signal path can be quickly and automatically done using the internal calibration source to eliminate errors introduced by the signal path through the SCPs and FET MUX, or by ambient temperature changes. All input channels can be quickly and productively calibrated to assure continued high-accuracy measurements.

In addition to the calibration of the signal path within the measurement and control module, the VT1419A allows you to perform a "Tare Cal" to reduce the effects of voltage offsets and IR voltage drops in your signal wiring that is external to the measurement and control module. The Tare Cal uses an on-board D/A to eliminate these voltage offsets. By placing a short circuit across the signal or transducer being measured, the residual offset can be automatically measured and eliminated by the D/A. Tare Cal should not be used to eliminate the thermoelectric voltage of thermocouple wire on thermocouple channels.

#### Signal Conditioning Plug-Ons

A Signal Conditioning Plug-on (SCP) is a small daughter board that mounts on VXI Technology's VXI scanning measurement and control modules. These SCPs provide a number of input and output functions. Several include gain and filtered analog inputs for measuring electrical and sensor-based signals, as well as frequency, total event count, pulse-width modulation, toothed-wheel velocity, and digital state. Output functions include analog voltage and current D/As, 8- or 16-bit digital outputs, pulse output with variable frequency and PWM, and stepper motor control.

Refer to the information on each individual SCP for more details.

#### Voltage Measurements

Use any of the following SCPs with the VT1419A to make voltage measurements: VT1501A, E1502A, VT1503A, VT1508A, VT1509A, VT1512A, or VT1513A.

## Multifunctional<sup>Plus</sup> Measurement and Control Module

### Temperature Measurements

Any of the input SCPs can be used to make temperature measurements with thermocouples, thermistors, or RTDs, but the VT1503A/VT1508A/VT1509A SCPs provide higher accuracy with thermocouples.

### Resistance Measurements

Resistance is measured using either the VT1505A 8-channel Current Source SCP and an input SCP or the VT1518A 4-wire Resistance Measurement SCP. Measurements are made by applying a dc current to the unknown and measuring the voltage drop across the unknown.

### Static Strain Measurements

The VT1506A and VT1507A SCPs provide a convenient way to measure a few channels of static strain. When using the VT1506A/VT1507A for Bridge completion, a second SCP is required to make the measurement. You can use the following SCPs for this type of static strain measurements:

- VT1503A 8-channel Programmable Filter/Gain SCP
- VT1506A 8-channel 120  $\Omega$  Strain Completion & Excitation SCP
- VT1507A 8-channel 350  $\Omega$  Strain Completion & Excitation SCP
- VT1508A 8-channel 7 Hz Fixed Filter & x16 Gain SCP
- VT1509A 8-channel 7 Hz Fixed Filter & x64 Gain SCP

For applications requiring large channel counts of strain measurement, the EX1629 provides a more cost effective approach to static (and dynamic) strain measurements.

### Transient Measurements

When making higher speed measurements, a vital issue often is the time skew between channels. Ideally, in many applications, the sampled data is needed at essentially the same instant in time. The intrinsic design of the VT1419A provides scanning of 64 channels with maximum skew of 640  $\mu$ s between the first and last channel, far less than most sampled data systems.

### Transient Voltage Measurements

The VT1510A provides basic sample-and-hold capabilities on four channels. Six-pole Bessel filters provide alias and alias-based noise reduction while giving excellent transient response without overshoot or ringing. The VT1510A can be used in strain applications primarily where the bridge is external.

### Transient Strain Measurements

The VT1511A, a double-wide SCP, has all the capabilities of the VT1510A but adds on-board bridge excitation and completion functions. The four direct input channels are used for monitoring the bridge excitation. A maximum of two SCPs (8 channels) can be installed on an VT1419A. Note: For field wiring, the use of shielded twisted pair wiring is highly recommended.

### Analog Output

Use the VT1531A for voltage outputs and the VT1532A for current outputs. The VT1531A and VT1532A have eight (8) output channels available on each SCP.

### Digital I/O

Use the VT1533A Digital I/O SCP to provide two 8-bit input/output words. Use the VT1536A Digital I/O SCP to provide one isolated 8-bit input/output word.

### Frequency/Totalize/PWM

The VT1538A Enhanced Frequency/Totalize/PWM SCP provides eight (8) channels which can be individually configured as a frequency or totalizer input, or as a pulse width modulated output.

## Product Specifications

### Timing Signals

<b>Timing:</b>	Scan-to-scan timing and sample-to-sample timing can be set independently.
<b>Scan triggers:</b>	Can be derived from a software command or a TTL level from other VXI modules, internal timer, or external hardware. Typical latency 17.5 $\mu$ s.
<b>Synchronization:</b>	Multiple VT1419A modules can be synchronized at the same rate using the TTL trigger output from one VT1419A to trigger the others.
<b>Alternate synchronization:</b>	Multiple VT1419A modules can be synchronized at different integer-related rates using the ALG:SCAN:RATIO command and the TTL trigger output from one VT1419A module to trigger the others.
<b>Scan Triggers Internal:</b>	100 $\mu$ s to 6.5536 s

## Multifunctional<sup>Plus</sup> Measurement and Control Module

<b>Resolution:</b>	100 $\mu$ s
<b>Trigger count:</b>	1 to 65535 or infinite
<b>Sample Timer Range:</b>	10 $\mu$ s to 32768 ms
<b>Resolution:</b>	0.5 $\mu$ s

### Measurement Specifications

The following specifications include the SCP and scanning A/D performance together as a unit. Accuracy is stated for a single sample. Averaging multiple samples will improve accuracy by reducing noise of the signal. The basic VT1419A scanning A/D has a full-scale range of  $\pm 16$  V and five auto-ranging gains of x1, x4, x16, x64, and x256. An SCP must be used with each eight channel input block to provide input protection and signal conditioning.

Note: For field wiring, the use of shielded twisted pair wiring is highly recommended.

**Measurement resolution:** 16 bits (including sign)

**Maximum reading rate:** Up to 56 kSamples/s dependent upon configuration

**Memory:** 64 kSamples

**Maximum input voltage:** Normal mode plus common mode

Operating:  $< \pm 16$  V peak  
Damage level:  $> \pm 42$  V peak

**Maximum common mode voltage:**

Operating:  $< \pm 16$  V peak  
Damage level:  $> \pm 42$  V peak

**SCP input impedance:**  $> 100$  M $\Omega$  differential

**Maximum tare cal offset:** 65.5 mV range  $\pm 75\%$  of full scale, other ranges  $\pm 25\%$  of full-scale

### Jitter:

**Phase jitter scan-to-scan:** 80 ps rms

**Phase jitter card-to-card:** 41 ns peak, 12 ns rms

### Measurement Accuracy

Typically  $\pm 0.01\%$  of input level; varies with the SCP used. Specifications are 90 days, 23  $^{\circ}$ C  $\pm 1$   $^{\circ}$ C, with \*CAL done after a 1hr warm-up and CAL:ZERO done within 5 minutes. Note: Beyond the 5min. limitation and CAL:ZERO not done, apply the following drift error: Drift = 10 V/ $^{\circ}$ C  $\div$  SCP gain, per  $^{\circ}$ C change from CAL:ZERO temperature.

### Accuracy Data

Measurement accuracy is dependent upon the SCP module used. Refer to the accuracy tables and graphs for the individual SCP to determine the overall measurement accuracy.

Many definitions of accuracy are possible. Here, we use single-shot with 3 sigma noise. To calculate accuracy assuming temperature is held constant within  $\pm 1$   $^{\circ}$ C of the temperature at calibration, the following formula applies:

$$\text{Single Shot } 3\sigma = \pm(\sqrt{(\text{GainError})^2 + (\text{OffsetError})^2} + (3\sigma \text{ noise})^2)$$

### Correcting for Temperature

To calculate accuracy over temperature range outside the  $\pm 1^{\circ}$  C range, results after \*CAL are given by replacing each of the above error terms as follows:

Replace  $(\text{GainError})^2$   
with  $(\text{GainError})^2 + (\text{GainTempco})^2$

Replace  $(\text{OffsetError})^2$   
with  $(\text{OffsetError})^2 + (\text{OffsetTempco})^2$

### Power Available for SCPs

$\pm 24$ V:	1.0 A
5 V:	3.5 A

### General Specifications

**VXI device type:** A16, slave only, Register based

**Size:** C

**Slots:** 1

**Connectors:** P1/2

**VXI buses:** TTL Trigger bus

**Drivers:** VXIplug&play with Source Code

Instrument Drivers - See the VXI Technology Website [www.vxitech.com](http://www.vxitech.com) for driver availability and downloading.

## Multifunction<sup>Plus</sup> Measurement and Control Module

### Ordering Information

VT1419A	Multifunction Plus measurement and control module
VT1419A-001	Delete 4 Direct Input SCPs
VT1419A-011	Screw Terminal Block
VT1419A-013	Spring-Clamp Terminal Block
VT1419A-A3F	Interface to Rackmount Panel
VT1501A**	8-channel Direct Input SCP
VT1502A**	8-channel 7 Hz Low-pass Filter SCP
VT1503A	8-channel Programmable Filter/Gain SCP
VT1505A	8-channel Current Source SCP
VT1506A	8-channel 120 Ω Strain Completion & Excitation SCP
VT1507A	8-channel 350 Ω Strain Completion & Excitation SCP
VT1508A**	8-channel x16 Gain & 7 Hz Fixed Filter SCP
VT1509A**	8-channel x64 Gain & 7 Hz Fixed Filter SCP
VT1510A	4-channel Sample & Hold Input SCP
VT1511A	4-channel Transient Strain SCP
VT1512A**	8-channel 25 Hz Fixed Filter SCP
VT1513A**	8-channel ÷ 16 Fixed Attenuator & 7 Hz Low-pass Filter SCP
VT1518A	4-wire Resistance Measurement SCP
VT1521	4-channel High Speed Bridge SCP
VT1531A	8-channel Voltage Output SCP
VT1532A	8-channel Current Output SCP
VT1533A	16-bit Digital I/O SCP
VT1536A	8-bit Isolated Digital I/O SCP
VT1538A	Enhanced Frequency/Totalize/PWM SCP

<sup>1</sup> Note: No terminal block is included with the VT1419A. You must specify a terminal block option when ordering.

<sup>2</sup> Note: A total of eight (8) Signal Conditioning Plug-ons (SCPs) can be installed in multiple combinations of input or output configurations on a single VT1419A. The first four positions support only the non-programmable analog input SCPs (marked with asterisks [\*\*] in the Ordering Information table). The VT1419A is shipped preconfigured with the VT1501A direct inputs in the first four SCP positions. Any non-programmable input SCP marked with asterisks (\*\*) may be substituted by ordering Option 001 with the VT1419A, then purchasing the SCP separately.

#### For More Information

For more information on individual SCPs, refer to the corresponding catalog pages for those products, or contact VXI Technology to request individual data sheets.

#### ACCESSORIES

73-0025-002 Option 011 Screw Terminal Connector Block

73-0025-003 Option 013 Spring Clamp Terminal Connector Block

73-0025-004 Option A3F Interface to Rackmount Terminal Panel

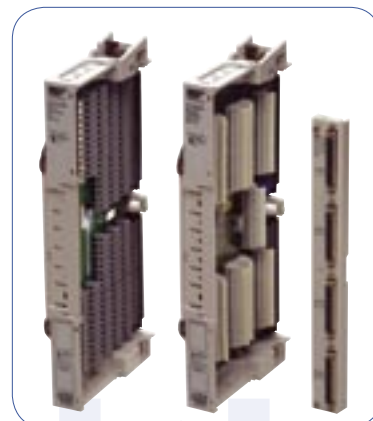

VT1419A